

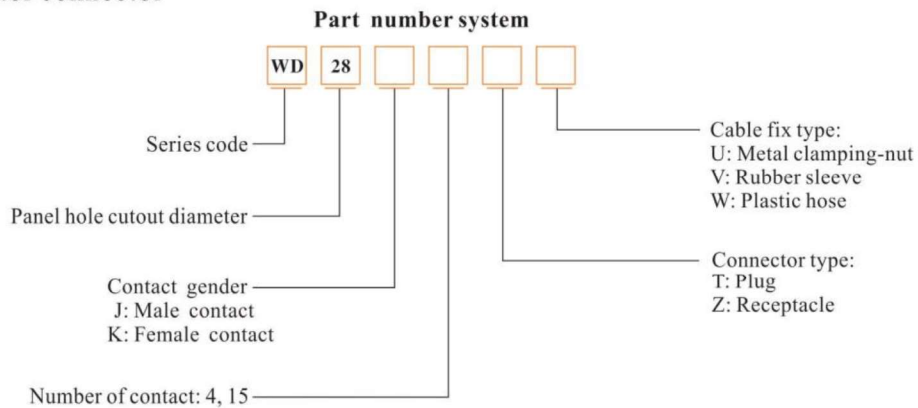

● WD Series IP55/IP65 Servo motor connector



★ These connectors are designed for servo motors, socket is IP65 without mating or cap, there is a layer of rubber-seal-insert stops water goes back of socket.

Material and spec

Coupling	Threaded
Shell material	Zinc alloy with black nickel plating
Insert material	Plug: PPS, max temperature 260°C Socket: Rubber and PPS, max temperature 260°C
Contact material	Brass with gold plating
Termination	Solder
Mating cycle	500
Temperature range	-40°C ~ +85°C
Insulation resistance (MΩ)	2000



● Receptacle: Z IP65

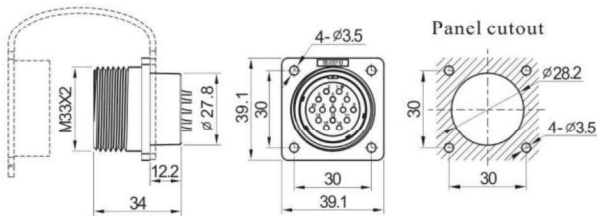

● Cable connector with clamping-nut: TU IP65

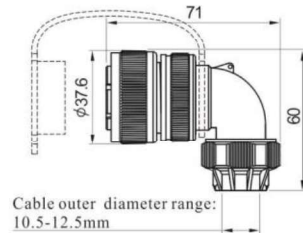

● Cable connector for plastic hose: TW IP55

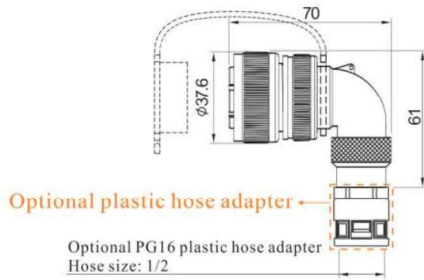

● Cable connector with with rubber sleeve: TV IP65

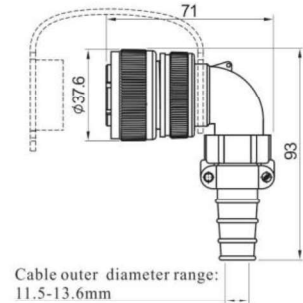

Solder contact spec

Number of contact	4	15
Male contact face view		
Rated current (A)	50 25	10
Contact diameter (mm)	3.5 2.5	1.5
Rated voltage (AC.V)	500	500
Test voltage(AC.V) 1 min	1500	1500
Contact resistance (mΩ)	0.5 1	2.5
Wire size (mm ² / AWG)	≤ 10 / 7 ≤ 4 / 11	≤ 2 / 14